

# Diesel Powered Generating Sets

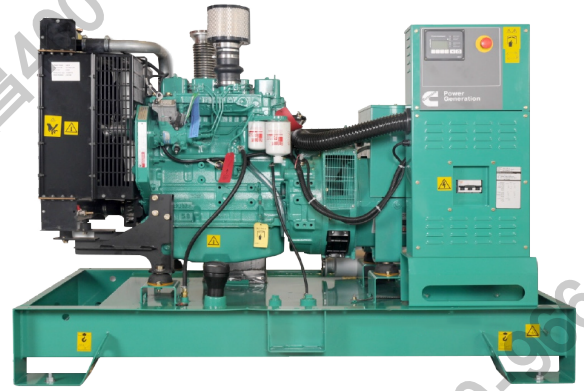

## C145D6



Our energy working for you.™

### Standard Genset Features

Cummins water cooled Diesel engine,  
Oil and fuel filter fitted, water separator,  
Lube-oil drain valve fitted  
Electric starter and Charge alternator 12 VDC.  
Electronic governor  
Normal duty air filter  
Single bearing alternator  
Set mounted starting battery  
Engine, Alternator, Chassis and Control  
Command House color: Munsell Jade Green  
Radiator and Guarding in color: Black  
Packing under shrunk plastic film  
Operation and Maintenance manual  
Standard set of labels  
Fuel tank in skid - day tank.

### Optional

#### PMG (Permanent Magnet Generating)

Offers enhanced motor starting, good performance with non-linear loads and faultclearing short circuit capability.

### Warranty Standard

Warranty 2 years (Standby)

### Exhaust Options

Exhaust silencer - Industrial 09 dB(A)  
Exhaust silencer - Residential 29 dB(A)

### Warranty

Warranty 5 years extended - (Standby)

### Fuel consumption

### Generator Set Performance

#### Voltage Regulation

Maintains voltage output within  $\pm 1,0\%$  in the following conditions:

1. At any power factor between 0.8 and 1.0
2. At any load level from no load to full load.
3. At speed droop variations up to 4,5%.

#### Frequency Regulation

Isochronous under any load, from no load to 100% full load when electronic governor is fitted.

#### Random Frequency Variation

Will not exceed  $\pm 0,25\%$  of rated frequency value for constant loads, no load to full load.

### Compliance Standards

To BS4999/5000 pt 99,  
VDE 0530, UTE5100,  
NEMA MG1-22, CEMA,  
IEC 34, CSA A22.2,  
AS1359, BSS 5514,  
ISO 3046 and ISO 8528

### Generator Set Options

#### Options

Coolant heater  
Battery Charger  
Automatic Transfer Switches - GTEC  
Silencer Enclosures  
External Tank  
Heavy Duty air filter

### Alternator Specification

#### Type

Brushless single bearing, revolving field, four pole.  
Protection from water (dripping).  
Class H Insulation, IP23 Protection.  
Vacuum impregnation.  
IC 01 cooling system.  
Fully interconnected damper winding.  
AC exciter and rotating rectifier unit.  
Epoxy coated stator winding.  
Rotor and exciter impregnated with polyester resin appropriate to the tropical climate, resistant to oil and acids.  
Rotor balanced dinamically BS 5625 2,5 degrees.  
Rotor wound in layers and with mechanics coins.  
Permanent lubricant ball bearing

#### Exciter

Triple dipped in moisture, oil and acid varnish and coated with anti-tracking varnish.

#### Winding

Low reactance 2/3 pitch windings; low waveform distortion with non-linear loads, fault clearing short-circuit capability.  
Engine/alternator direct coupling for perfect alignment.

### Voltage Connections - 60 Hz

480/277 V 380/220 V 220/127 V  
440/254 V 240/139 V 208/120 V  
416/240 V

Ratings	Standby				Prime			
	181 kVA		145 kW		N/A kVA		N/A kW	
Load	Full	3/4	1/2	1/4	Full	3/4	1/2	1/4
Consumption (L/hr)	41	31	22	12	N/A	N/A	N/A	N/A

N/A = Not Available

### Observation:

The engine above was tested according to the ISO-3046 respecting the following conditions:

Barometric Pressure = 100 kPa (29.83 in Hg)

Altitude above sea level = 110 m (316 ft)

Ambient temperature = 25° c (77° F)

Relative humidity = 30%

## Technical Data

<b>Model</b>	<b>C145D6</b>	<b>Alternator voltage regulation</b>	± 1.0%
<b>Standby Rating</b>	181 KVA / 145 KW	<b>Alternator insulation class</b>	H
<b>Prime Rating</b>	N/A	<b>IP Protection</b>	IP 23
<b>Engine Make</b>	Cummins	<b>Fuel consumption (Standby)</b>	41 l/h
<b>Engine Model</b>	6BTA 5.9-G2	<b>Fuel consumption (Prime)</b>	N/A
<b>Cylinders</b>	6 cylinders	<b>Lubrication system oil capacity</b>	16.4 l
<b>Engine Build</b>	In line	<b>Coolant capacity (only engine)</b>	9.9 litros
<b>Standard Governor/Class</b>	Electronic	<b>Coolant capacity (engine and radiator)</b>	23.7 litros
<b>Aspiration and cooling</b>	Turbocharged	<b>Exhaust temperature (Prime)</b>	550 °C
<b>Bore and stroke</b>	102 mm x 120 mm	<b>Exhaust gas flow (Prime)</b>	537 l/s
<b>Compression Ratio</b>	16.5 : 1	<b>Exhaust gas back pressure max</b>	76 mm Hg
<b>Cubic capacity</b>	5.88 liters	<b>Air flow radiator</b>	5.43 m³/s
<b>Starting/Min °C</b>	Unaided / -12°C	<b>Intake air flow</b>	205 l/s
<b>Battery capacity</b>	(1x) 100 A/h	<b>Minimum air opening to room</b>	0.7 m²
<b>Gross Engine output – Standby</b>	164 kWm	<b>Minimum discharge opening</b>	0.5 m²
<b>Gross Engine output – Prime</b>	N/A	<b>Radiated heat to ambient</b>	25.4 kWm
<b>Speed</b>	1800 rpm	<b>Tank incorporated in the base capacity</b>	250 litros

### STANDBY POWER RATING (ESP)

The Standby Power Rating is applicable for supplying emergency power for the duration of a utility power interruption. No overload, utility parallel or negotiated outage operation capability is available at this rating. In installations served by unreliable utility sources (where outages last longer or occur more frequently), where operation is likely to exceed 200 hours per year, the prime power rating should be applied.

### PRIME POWER (PRP)

Prime power is available for an unlimited number of annual operating hours in variable load applications, in accordance with ISO8528-1. A 10% overload capability is available for a period of 1 hour within a 12-hour period of operation.

### All ratings are based on the following reference conditions:

- Ambient temperature: 27°C

- Altitude above sea level: 150 meters

- Relative humidity: 60%

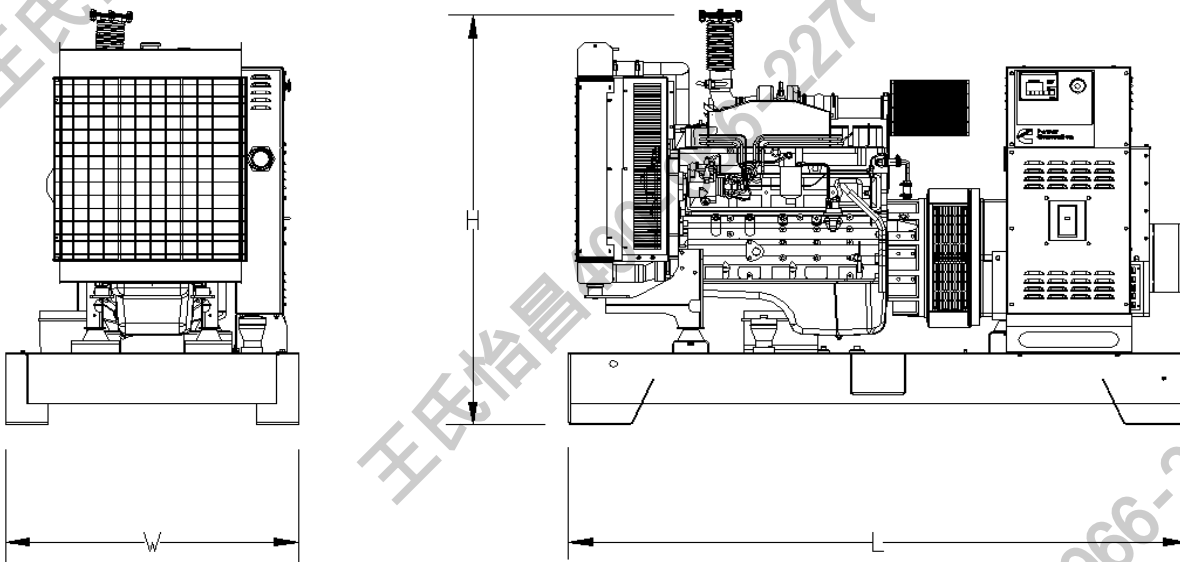

This outline drawing is for reference only. Do not use for installation design

### Dimensions and Weights

Genset	Length (mm) L	Width (mm) W	Height (mm) H	Set weight dry (kg)	Set weight wet (kg)*
Open Set	2220	1050	1560	1310	1564
Carenagem - F190	3143	1090	1865	1889	2101

\*Set weight wet represent a set with oil, fuel and coolant liquid.



Wangshi Yichang dealer  
Zip Code: 518000  
Phone: (86) 400-966-2276  
www.szwsyc.cn

the  
**Power**  
of One

See your distributor for more information.

